



Expertise – Passion – Automation



Life Science

Our products for your application

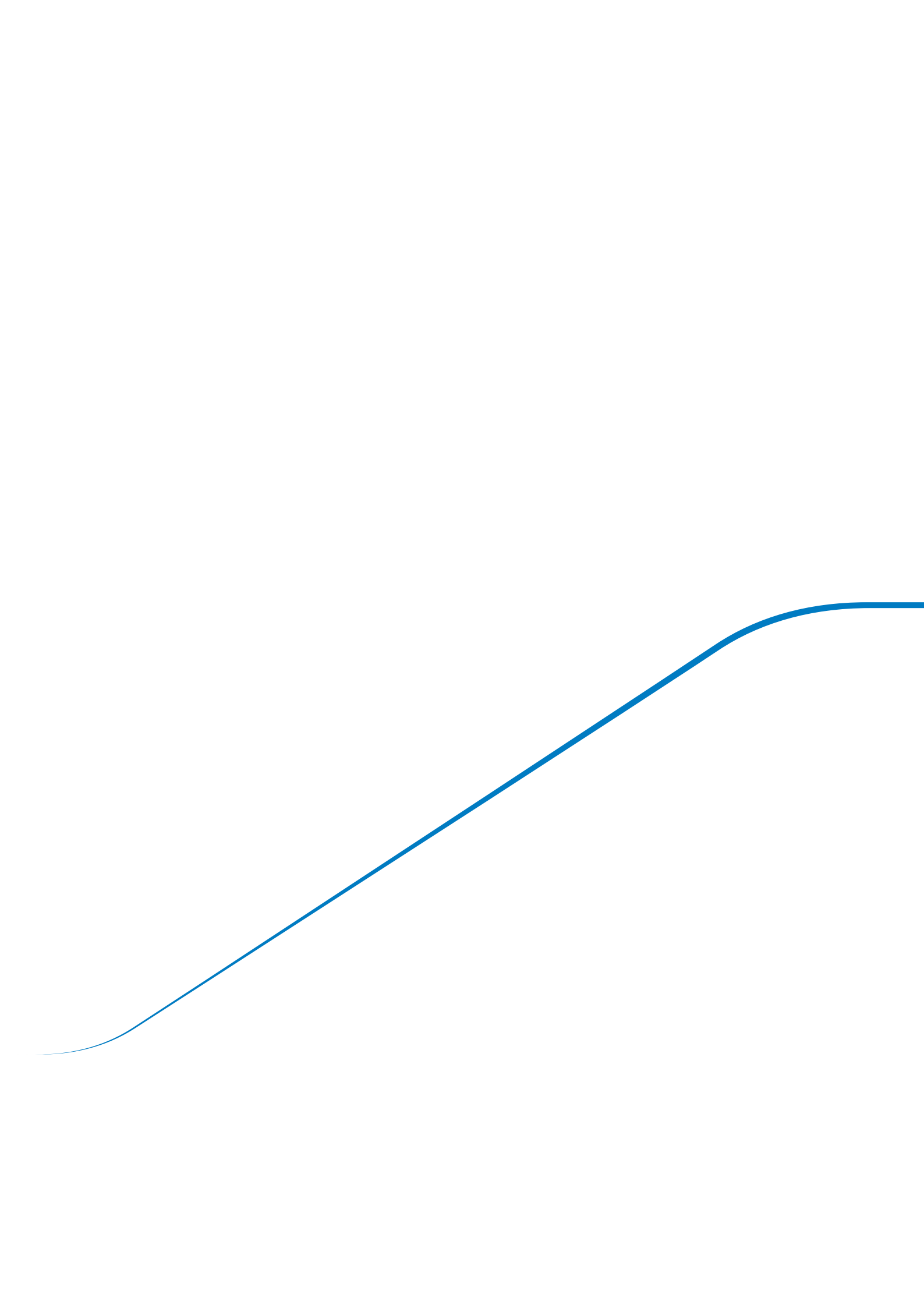



SMC – Your automation partner for the Medical Device & Life Science industry

SMC is a world leader in innovative design of automation components specifically suited to the Medical Device and Life Science Industry.

Our global network of sales and services, covering over 83 countries, is supported by an expansive manufacturing capacity in order to meet our customers' needs.

We offer over 700,000 products that include technologies for pneumatic and robotic automation, microfluidics, thermo control, high purity liquid and gas, among many others.

Custom design, total solution and component quality are part of our DNA.

Our components... for the life of your device.

How can SMC help you?

Analysers



Custom engineered solution

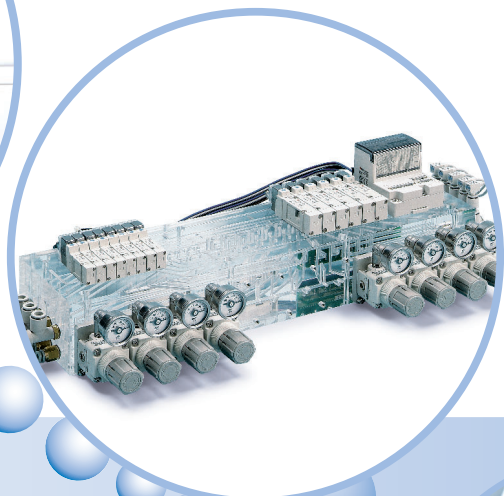

Lab automation

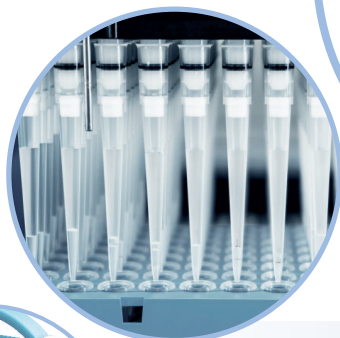

Oxygen concentrator



Compression care & NIBP



Sterilisers & Decontamination



Pharmaceutical & Bio-Pharma

Dental applications



X-Ray & MRI systems

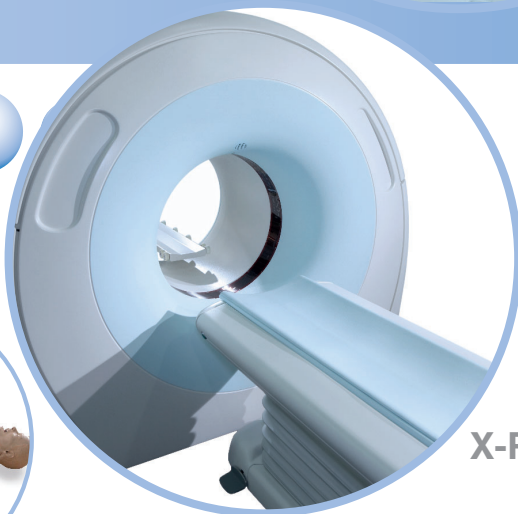

Medical training simulators

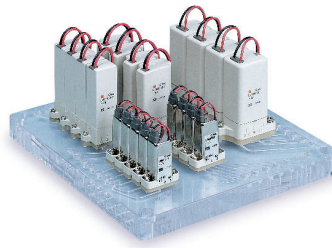

Engineered manifolds and assemblies

Reduced connection leakage, save space and assembly labour.



Chemical inert isolation valves

Zero dead volume.
Low power consumption.



Fixed shot solenoid pump

Accurate, repeatable liquid dispensing.

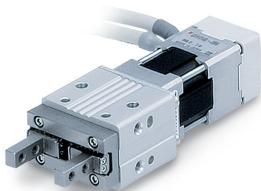

Electric robot hand

Miniature, lightweight and space saving.

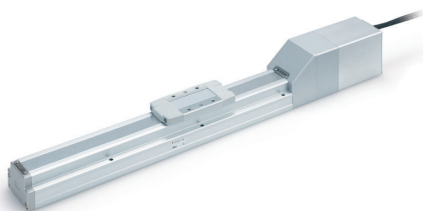

Electric linear actuators

Precision motion, high-speed and quiet movement in a compact space.



Electric rotary actuators

Compact, precision rotary motion.



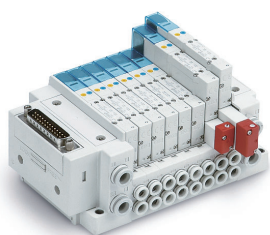

Solenoid directional control valves

Compact, high flow, power-saving pneumatic pick and place controls.



Digital pressure and flow sensor

Measure condition, programme values and alarm points. Remote output features.

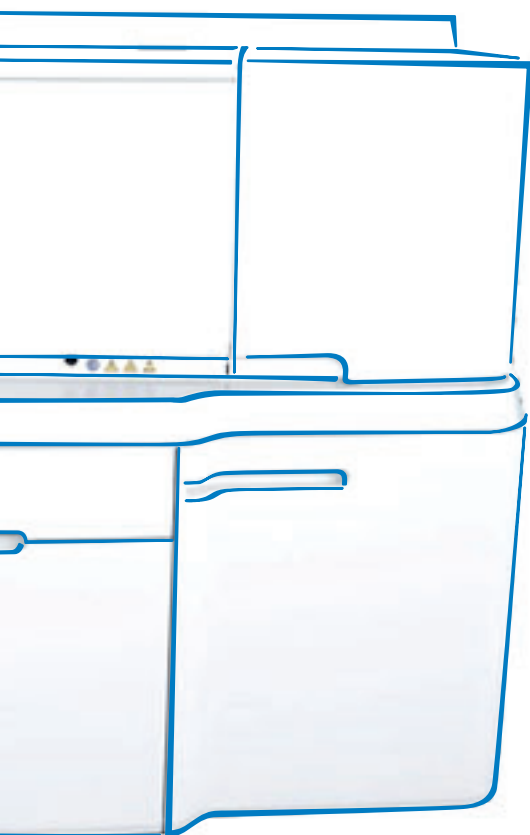

Air preparation equipment

Eliminate maintenance and reduce costs with filtration, drying and efficient pressure control.



Membrane air dryer

Sub-zero dew point delivers clean, dry air without electrical power.



Refrigerant and peltier style chillers

Efficient cooling for assays and increased reagent life. Precision control and sub zero temperatures.



Static removing ionizers

Eliminate blockages due to static electricity in component (e.g. cuvette) feeder devices.



Solenoid operated pinch valves

High flow, low power, zero dead volume liquid control.

Dental applications

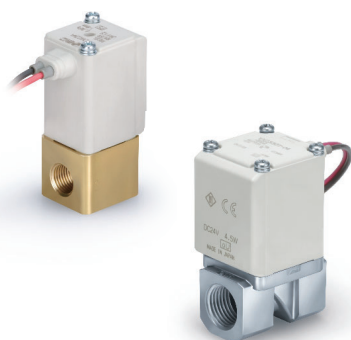

VX and VDW 2 & 3-port media solenoid valves

Energy saving as a consequence of low power solenoids.

Low switching noise suitable for use in quiet environments.

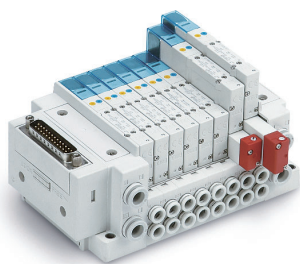

SY 5-port solenoid valves

Simple and quick valve replacement.
Different valve functions in a common manifold.

Flexible port configuration reducing installation costs and assembly time.
Reduced power consumption.



WR110 Water regulator

Tamperproof, lockable adjustment handle.

Resilient body and seal materials assure long service life.



AC-B Modular F.R.L. units

Improved visibility and options.
Modular design incorporating many functions.
Improved resistance to chemicals and other substances.



PVQ Proportional solenoid valves

Greater process control.
Extended service life.
Can be used in quiet environments.



WF300 Water strainer

Extends the service life of downstream products.
Simple maintenance due to replaceable mesh.
Resilient body and seal materials.



IDG Membrane air dryers

High and accurate air drying capacity.
Reduction of air preparation process time.
Onboard filter monitor.
No electrical running costs.
Suitable for use in confined spaces.
Long service life.



VX and VDW 2 & 3-port media solenoid valves

High flow capacity.
Energy saving as a consequence of low power solenoids.
Low switching noise suitable for use in quiet environments.



APTech series: High pressure & High purity products

Wide range of gas valves and regulators.



LQ High purity fluoropolymer fitting

Wide range of sizes and forms.
High leakage protection.
Superior chemical and heat resistance.
Easy assembly.



VXZ 2-port solenoid valves

Suitable for use in low pressure fluid and low vacuum applications due to the zero differential pressure construction.
Ideal for use in quiet environments due to low switching noise.





Fluoropolymer tubing

High chemical and heat resistance.
Wide range of size variations.
Easy and quick assembly process.



VXB Angle seat valves

Robust, compact construction.
Range of body materials.
Reliable long life sealing system.

Oxygen concentrators



SRA Regulator

The SRA regulator can be pre-set and left alone for the life of the device, providing repeatable pressures with low hysteresis.

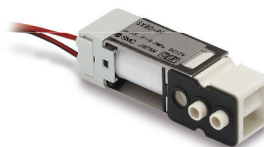

SX90 2-port and SX090 3-port valve

The 2-port and 3-port SX series valve can be used to control fill/exhaust, as well as crossover function and oxygen delivery in portable oxygen concentrator applications.

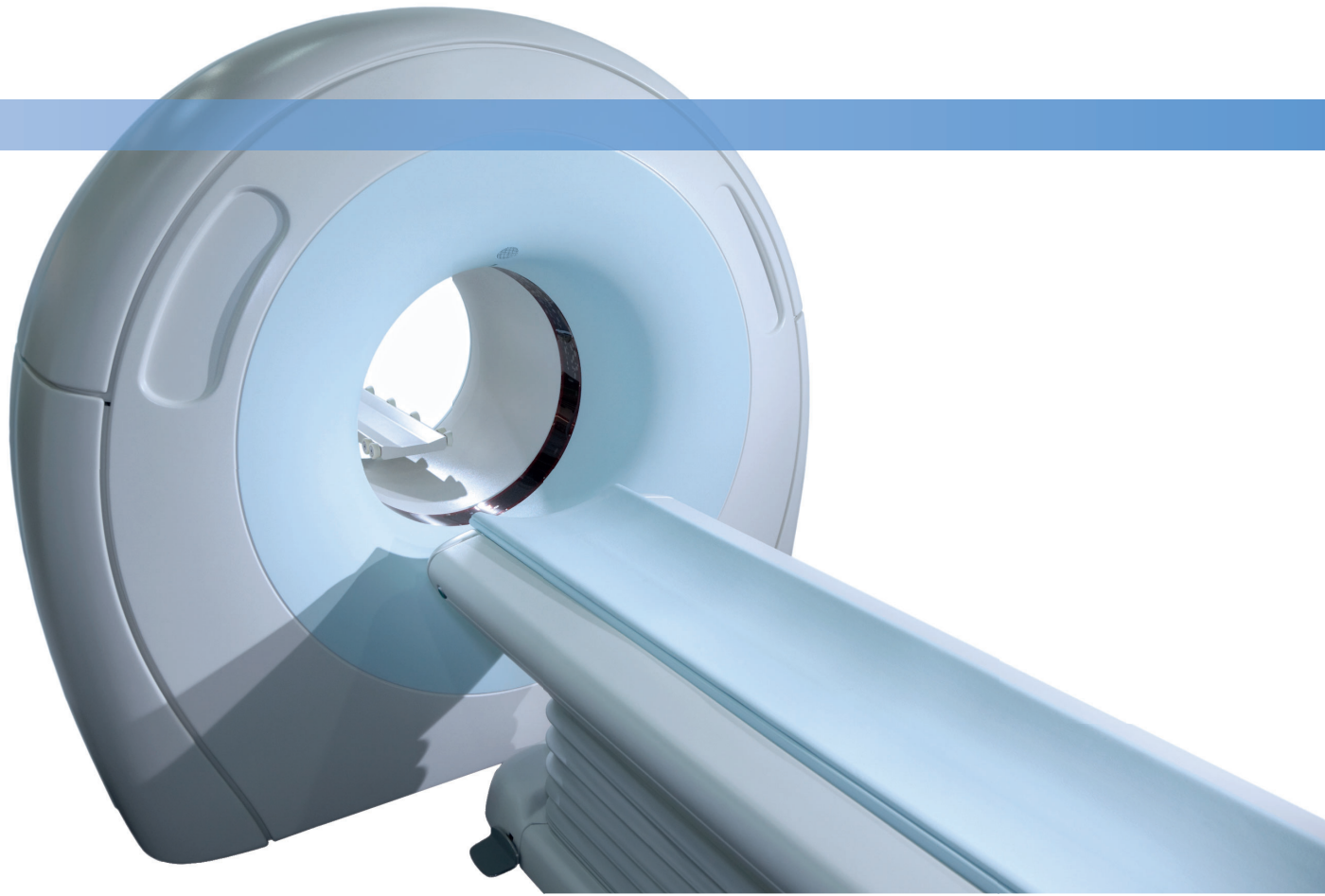

KKA S couple

Highly corrosion resistant.
Robust design and construction.
Wide range of size variations.



PF3W Flow switch

High accuracy and repeatability.
Highly visual multi-colour display.
IO-Link compatible.
Integrated product diagnostics.
Remotely accessible and tamper-proof.



HRS Thermo-chiller

Superior temperature stability across a range of ambient conditions.
Reduced envelope dimensions for fitting in restricted machine space.
Easy operation, control and maintenance.



HEC Peltier thermo-con

Superior temperature stability and control.
Environmentally-friendly (refrigerant-free).
Heaterless.

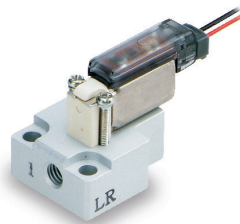

S070 3-port solenoid valve

Miniature and lightweight design (7 mm body width).
Energy-saving circuit reduces heat and power consumption.
Reduced switching noise.



V100 3-port solenoid valve

Miniature design (body width of 10 mm).
Energy-saving circuit reduces power consumption.
Lightweight.

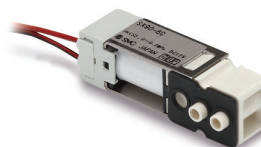

SX90 High flow solenoid valve

The 2-port and 3-port SX series valves have many of the features of the V100 and S070 valves with the additional benefit of increased flow capacity.

Medical training simulators



LVM Liquid isolation valves

Increased chemical resistance.
Low power consumption.
Zero dead volume.
Space saving.



CQ2 Compact cylinder

Compact, lightweight and robust design.
Multiple mounting options.



VDW 2-port media solenoid valves

High flow capacity.
Energy saving as a consequence of low power solenoids.
Low switching noise suitable for use in quiet environments.



PVQ Proportional solenoid valves

Greater process control.
Extended service life.
Can be used in quiet environments.

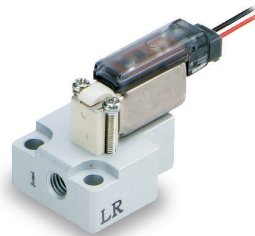

S070 3-port solenoid valve

Miniature and lightweight design (7 mm body width).
Energy saving circuit reduces heat and power consumption.
Reduced switching noise.



EX Serial transmission system

Fieldbus systems save on components, installation time, wiring and space. Communication in several languages. Ethernet-based Fieldbus systems and other common industrial communication protocols are available. All-to-all connection. Remote control & diagnostics.



CJ5-S/CG5-S Stainless steel cylinder

Highly resistant to corrosion. Clean design reduces liquid retention after washing. Cost efficient due to long service life.



VQC 5-port solenoid valves

Greater capacity, versatility and flexibility with new sizes, types and options. Increased wiring orientations and variations.



EX600-W Wireless system

Radically reduced wiring results in reduced installation cost and setting time. Enhanced machine and component flexibility. Safe, reliable and stable communication.



HY Hygienic design cylinder

Wash down compatible due to its streamlined design. Resilient body and seal materials ensure long service life. Many mounting options available.



KKA S couple

Highly corrosion resistant.
Robust design and construction.
Wide range of size variations.

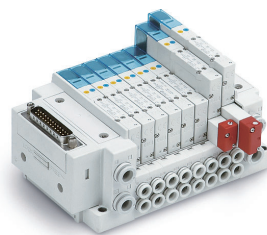

SY 5-port solenoid valves

Simple and quick valve replacement.
Different valve functions in a
common manifold.
Flexible port configuration reducing
installation costs and assembly time.
Reduced power consumption.

Custom engineered solutions

Composite bonded valve manifold for air, gas and liquids. Materials include acrylic, ultem, PVC and polycarbonate etc.

Space saving

With the reduction in piping volume, the manifold can be designed for confined spaces.

Reduced piping and connections

Integrated circuit reduces leakage and internal channel volume.

Reduced wiring

Wiring time reduced by integrating printed circuit boards to the manifold assembly.

Transparent flow passages

Easy visual detection of fluid or contamination.

Lightweight

Weight reduced by using a range of high-tech materials and by minimising overall size and rationalising components.

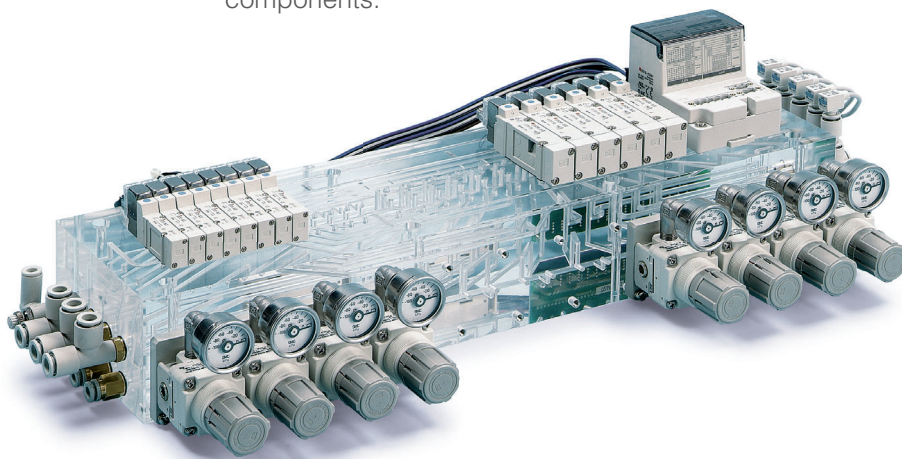

Flow passage style with high flexibility

Multi-layer flow passages allow for connections that cannot be created by machining or injection molding.

Current type (tube piping)

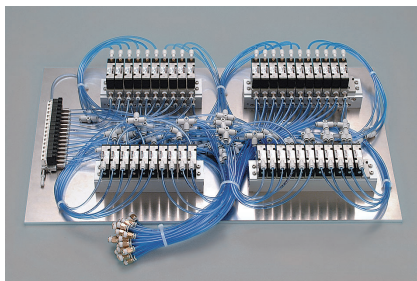

Composite manifold

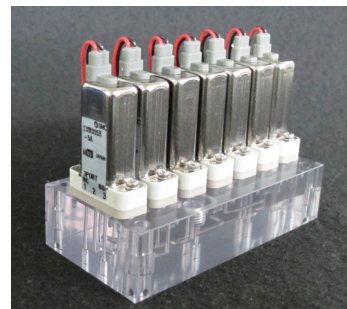
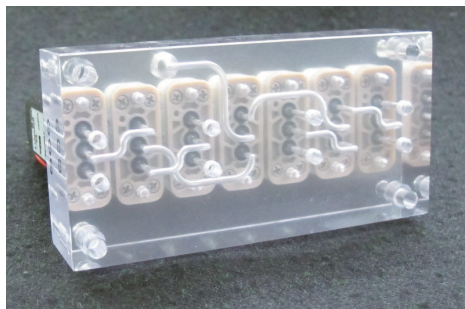
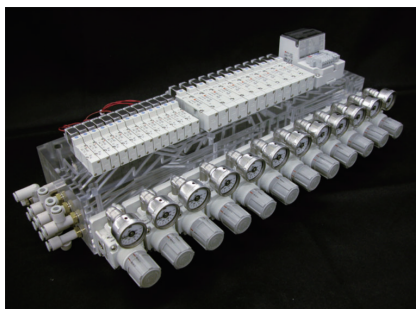
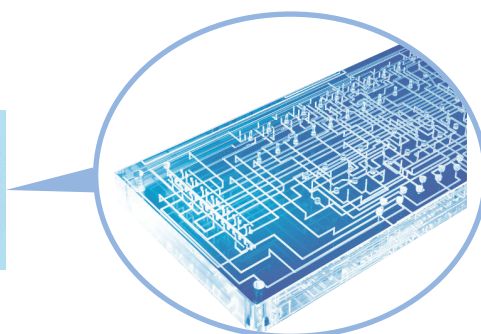
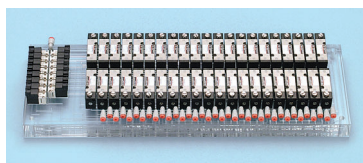

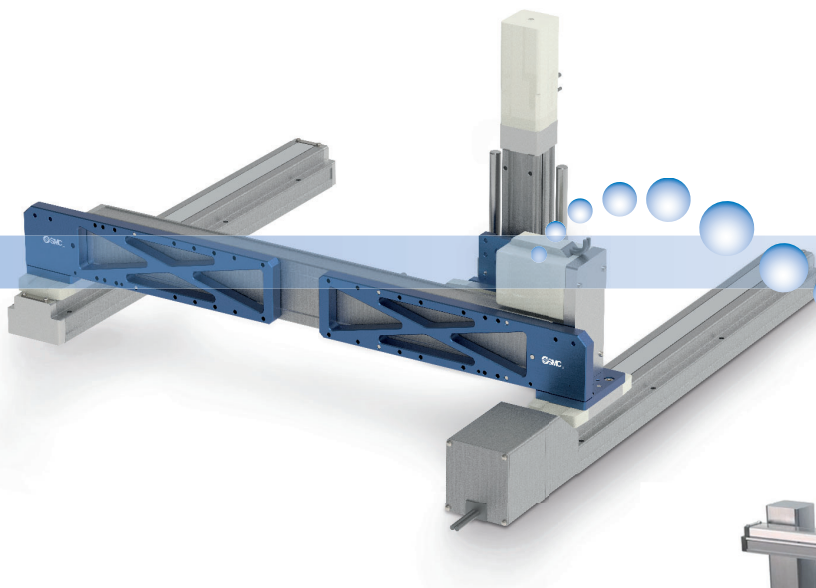
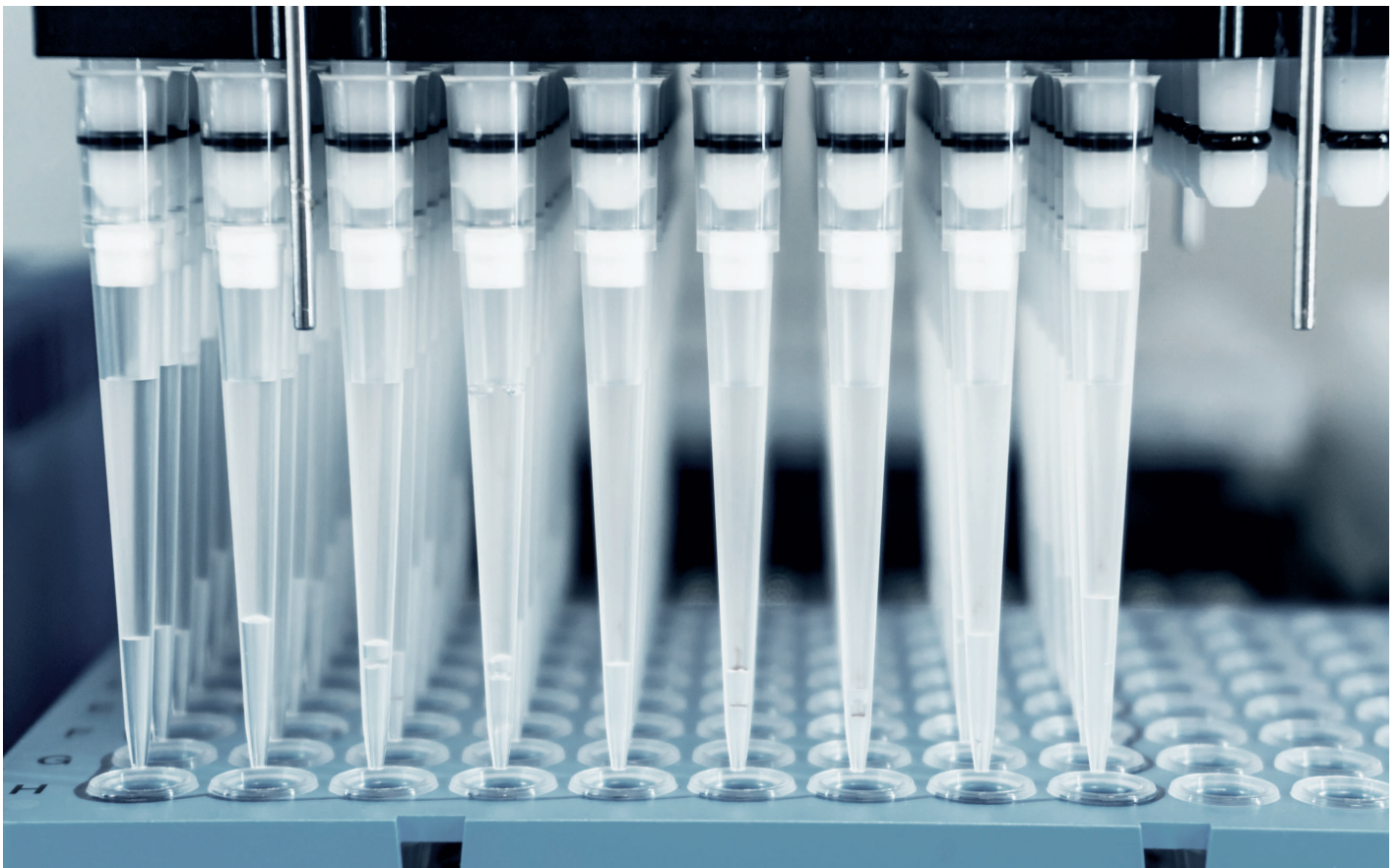

Laboratory automation

Helping to ensure you achieve maximum speed, accuracy, performance and efficiency. SMC provides specialised products for robotics, liquid handling, dispensing, sample management and vacuum handling.



Isolation valves



Liquid isolation valves



LVM Series

- Fluid: air, water, chemicals
- Valve type: NC, NO, universal
- Orifice size: 1.1 to 2 mm
- Long service life: 10 million cycles
- Wetted part material: PEEK, EPDM, FKM, FFKM.

Pinch valves



Pinch valves

LPV Series

- The fluid does not come into contact with the moving parts of the valve, so there is no inflow of contaminants
- By discarding a tube after use, the need for a washing process is eliminated, thus ensuring good hygiene
- Tubes can be set or replaced easily.

Dispense pump



Liquid dispense pump

LSP Series

- Solenoid driven diaphragm type
- Discharge volume: 5-200 uL/Shot
- Repeatability: $\pm 1\%$
- Max. frequency: 2 Hz
- Body ported or base mounted.

Ionizers



Bar type ionizer



IZS Series

- Effective and efficient in the rapid elimination of static
- Built-in, high accuracy and feedback sensors
- Energy saving and high speed de-ionizing cartridges
- Low maintenance electrode cartridges
- Electrostatic removal from flat surfaces and remote surfaces
- Suitable for applications in all industries.



Fan type ionizer



IZF Series

- Compact and lightweight
- Flow rate adjustment function
- Electrostatic removal in the atmosphere around a work piece
- Operates without the need of a compressed air supply
- Suitable for applications in all industries.

Nozzle type ionizer



IZN Series

- Slim design
- Built-in power supply substrate
- Energy saving and large flow nozzles
- Removal from a small work piece or total electrostatic removal in confined spaces. Suitable for dust removal
- Suitable for applications in all industries.

Electric actuators

Slider type

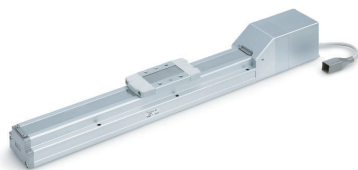

Ball screw drive

 LEFS Series

Step motor (servo/24 VDC), servo motor (24 VDC)

- Max. work load: 65 kg
- Positioning repeatability: ± 0.015 mm (high precision type)
- Clean specification: complies with ISO Class 4 (ISO 14644-1) (11-LEFS).

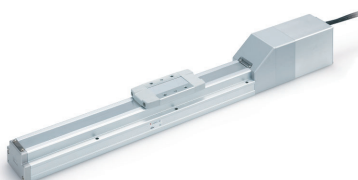

AC servo motor

- High output motor (100/200/400 W)
- Improved high speed transfer ability
- High acceleration/deceleration (20.000 mm/s²)
- Pulse input type
- Internal absolute encoder
- Positioning repeatability: ± 0.01 mm (high precision type)
- Clean specification: complies with ISO Class 4 (ISO 14644-1) (11-LEFS)
- Compatible drivers: LECSS-T, LECY
- Motorless specification is available.

Belt drive

 LEFB Series

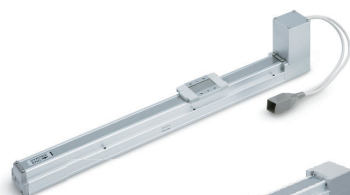

Step motor (servo/24 VDC), servo motor (24 VDC)

- Max. stroke: 2000 mm
- Max. speed: 2000 mm/s
- Positioning repeatability: ± 0.08 mm.



AC servo motor

- Max. speed: 2000 mm/s
- Max. stroke: 3000 mm
- Max. acceleration/deceleration: 20000 mm/s²
- Pulse input type
- With internal absolute encoder
- Positioning repeatability: ± 0.06 mm
- Compatible drivers: LECSS-T, LECY
- Motorless specification is available.

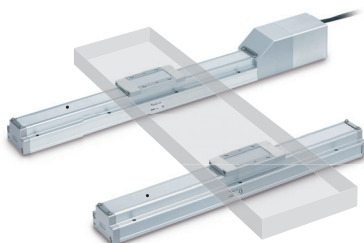

Support guide

 LEFG Series

- A support guide that is designed to support workpieces with significant overhang
- Easy installation with the same outer dimensions as the LEF series body - contributes to the reduction of design and assembly labour
- The standardly equipped sealing band prevents the scattering of grease and the entry of foreign matter from outside.

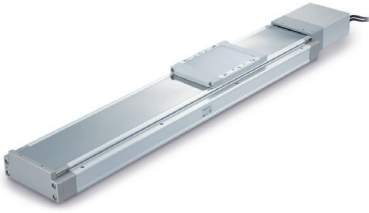

High rigidity slider type, ball screw drive

 LEJS Series

- Low profile/Low center of gravity: height reduced by approx. 36 % (reduced by 32 mm)
- Max. work load: 85 kg
- Positioning repeatability: ± 0.02 mm
- Max. acceleration/deceleration: 20000 mm/s^2
- Clean specification: complies with ISO Class 4 (Class 10) (11-LEJS)
- Compatible drivers: LECSS-T, LECY
- Motorless specification is available.

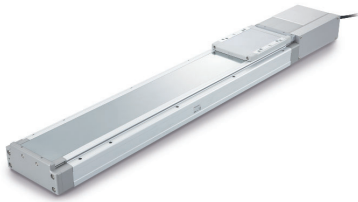

High rigidity slider type, belt drive

 LEJB Series

- Max. stroke: 3000 mm
- Max. speed: 3000 mm/s
- Max. acceleration/deceleration: 20000 mm/s^2
- Compatible drivers: LECSS-T, LECY
- Motorless specification is available.

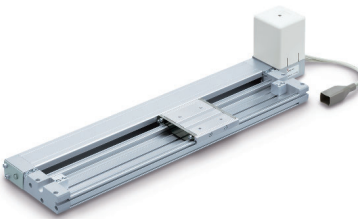

Low profile slider type

 LEM Series

- Low-profile, low centre of gravity
- Table height: 28 mm (in the case of LEMC/H/HT, size 25)
- Can be combined with various guides
- High maintainability
- Motor mounting position: select from above or below, right or left
- Solid state auto switches can be mounted for limit confirmation and intermediate signal confirmation
- Selectable controllability (controller)
- Complete control like an air cylinder (allows for a 12 point intermediate stop)
- Easy position setting by value input.



Guide rod slider, belt drive

 LEL Series

- Low profile/Flat: height 48 mm
- Profile reduced by the side mounting of the motor
- No interference with the motor, even with large workpieces
- Auto switch mountable (made to order)
- Max. stroke: 1000 mm
- Transfer speed: 1000 mm/s
- Positioning repeatability: ± 0.1 mm.

Rod type



Step motor (servo/24 VDC), servo motor (24 VDC)

 LEY/LEYD Series

Motor top/parallel type

- Long stroke: max. 500 mm
- Direct mounting: 3 directions
- Bracket mounting: 3 types
- Auto switch can be mounted
- Speed control/Positioning: max. 64 points
- Either positioning or pushing control can be selected.
- It is possible to hold the actuator with the rod pushing on a workpiece, etc.
- Positioning repeatability: ± 0.02 mm or less
- Dust-tight/Water-jet-proof (IP65).



In-line motor type

- Long stroke: max. 500 mm
- Direct mounting: 3 directions, bracket mounting: 3 types
- Auto switch can be mounted
- Speed control/Positioning: max. 64 points
- Either positioning or pushing control can be selected
- It is possible to hold the actuator with the rod pushing on a workpiece, etc.
- Positioning repeatability: ± 0.02 mm or less.

AC servo motor

 LEY/LEYD Series



Motor top/parallel type

- High output motor (100/200/400 W)
- Improved high speed transfer ability
- High acceleration compatible (5000 mm/s^2)
- Pulse input type
- With internal absolute encoder
- Positioning repeatability: ± 0.02 mm or less
- Dust-tight/Water-jet-proof (IP65 equivalent)
- Compatible drivers: LECSS-T, LECY
- Motorless specification is available.



In-line motor type

- High output motor (100/200/400 W)
- Improved high speed transfer ability
- High acceleration/deceleration compatible (5000 mm/s^2)
- Pulse input type
- With internal absolute encoder
- Positioning repeatability: ± 0.02 mm or less
- Compatible drivers: LECSS-T, LECY
- Motorless specification is available.

Guide rod type

Step motor (servo/24 VDC), servo motor (24 VDC)



LEYG/LEYGD Series

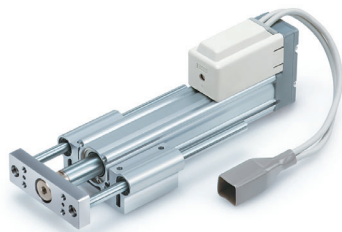

Motor top mounting type

- Compact integration of guide rods
- Achieves lateral load resistance and high non-rotating accuracy
- Lateral end load: five times more (compared with a rod type, size 25, 100 stroke)
- Compatible with sliding bearings and ball bushing bearings
- Compatible with moment load and stopper (sliding bearings)
- Speed control/Positioning: max. 64 points
- Either positioning or pushing control can be selected
- It is possible to hold the actuator with the rod pushing on a workpiece, etc.
- Positioning repeatability: ± 0.02 mm or less.



In-line motor type

- Compact integration of guide rods
- Achieves lateral load resistance and high non-rotating accuracy
- Lateral end load: five times more (compared with a rod type, size 25, 100 stroke)
- Compatible with sliding bearings and ball bushing bearings
- Compatible with moment load and stopper (sliding bearings)
- Speed control/Positioning: max. 64 points
- Either positioning or pushing control can be selected
- It is possible to hold the actuator with the rod pushing on a workpiece, etc.
- Positioning repeatability: ± 0.02 mm or less.

AC servo motor



LEYG/LEYGD Series

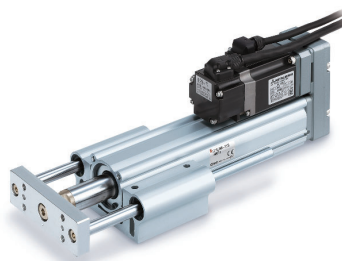

Motor top mounting type

- High output motor (100/200 W)
- Improved high speed transfer ability
- High acceleration/deceleration compatible (5000 mm/s^2)
- Pulse input type
- With internal absolute encoder
- Compatible drivers: LECSS-T, LECY
- Motorless specification is available.



In-line motor type

- High output motor (100/200 W)
- Improved high speed transfer ability
- High acceleration/deceleration compatible (5000 mm/s^2)
- Pulse input type
- With internal absolute encoder
- Compatible drivers: LECSS-T, LECY
- Motorless specification is available.

Slide table



Electric slide table/Compact type



- Compact: workpiece mounting surface height reduced by up to 12 % compared with the LESH
- Vertical work load: increased by up to 50 %
- Lightweight: reduced by up to 29 %
- Max. pushing force: 180 N
- Positioning repeatability: ± 0.05 mm
- Cycle time can be reduced.
- Max. acceleration/deceleration: 5000 mm/s^2
- Max. speed: 400 mm/s.



Electric slide table/High rigidity type



- Easy setting: data can be set with only 2 items, position and speed.
- The controller is already set with the data of the actuator (the actuator and controller are provided as a set)
- Integrated guide rail and table
- Uses a recirculating linear guide for high rigidity and high precision
- Reduced cycle time
- Max. acceleration/deceleration: 5000 mm/s^2 , max. speed: 400 mm/s
- Max. pushing force: 180 N
- Positioning repeatability: ± 0.05 mm.

Miniature



Miniature rod type



- Compact and lightweight
W 20.5 mm x H 30 mm x L 125.6 mm, weight 240 g
- Max. pushing force: 50 N
- Positioning repeatability: ± 0.05 mm
- It is possible to set the position, speed, and force. (64 points)
- Max. speed (horizontal): 350 mm/s.



Miniature slide table type



- Compact and lightweight
W 21 mm x H 41 mm x L 138.6 mm, weight 290 g
- Max. pushing force: 50 N
- Positioning repeatability: ± 0.05 mm
- It is possible to set the position, speed, and force. (64 points)
- Max. speed (horizontal): 350 mm/s.

Rotary table



Electric rotary table

 LER Series

- Rotation angle: 360°, 320° (310°), 180°, 90°
() The value indicated in brackets shows the value for the LER10
- Low profile: height 42 mm (LER10)
- Space saving: built-in step motor
- Shock less/high speed actuation
Max. speed: 42 0°/sec (7.33 rad/sec)
Max. acceleration/deceleration: 3000 °/sec² (52.36 rad/sec²)
- It is possible to set the speed, acceleration/deceleration, and position. Max. 64 points
- Energy saving: automatic 40 % power reduction after the table has stopped
- Easy setting: data can be set with only two items: position and speed.
The controller is already set with the data of the actuator (the actuator and controller are provided as a set).

Card motor

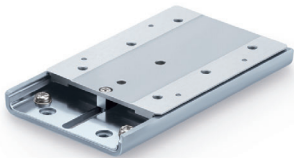

Card motor

 LAT3 Series

- The transportation, pushing, and length measurement systems have been miniaturized through the use of a linear motor
- Thickness 9 mm, weight 130 g (at a stroke of 10 mm)
- Max. pushing force: 6 N
- Positioning repeatability: ±5 μm
- Pushing measurement accuracy: ±10 μm
- Max. operating frequency: 500 cpm.

Grippers

- Easy setting: data can be set with only two items: position and force.
The controller is already set with the data of the actuator (actuator and controller are provided as a set)
- Equipped with a drop prevention function (all series come equipped with a self-lock mechanism)
- The self-lock mechanism reduces power consumption
- Equipped with a gripping check function
- It is possible to set the position, speed, and force (64 points).

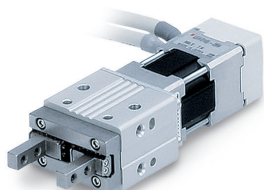

2-Finger type (Z type)

 LEHZ Series

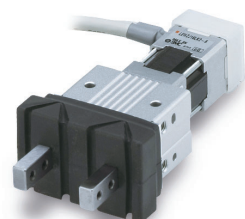

2-Finger type/With dust cover (ZJ type)

 LEHZJ Series

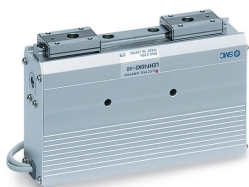

2-Finger type (F type)

 LEHF Series

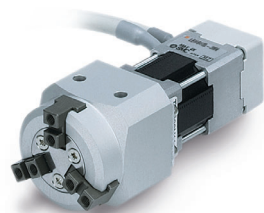

3-Finger type (S type)

 LEHS Series

Serial transmission

Fieldbus system

- Fieldbus system
 - Serial interface uses Fieldbus for communicating, instead of point-to-point connections, thus allowing savings in:
 - Material costs – cables, connectors, gutters
 - Connection and set-up times
 - Generation of electrical diagrams
 - Labelling and documentation
 - Electrical panels, cleaner and more compact – it is even possible to remove cabinets.
- Compatible with EtherNet/IP™-based and other common industrial protocols



- Short/open circuit detection
 - Easy to identify short circuits or open circuits.
- High environmental resistance
 - Up to IP67 enclosure protection
- Highlighted EX serial interface solutions:



Fieldbus system (Output device for driving 5-port solenoid valves)

 EX260 Series

- Centralised and compact solution for solenoid valves, with up to 32 outputs.



Fieldbus system (For input/output)

 EX600 Series

- Centralised and great capacity solution for both solenoid valves and I/O, with up to 512 inputs & 512.



Fieldbus system (Gateway decentralised type)

 EX500 Series

- Decentralised solution for both solenoid valves and I/O, with up to 128 inputs & 128 outputs.



Wireless system

 EX600-W Series

- Two SI units: wireless base SI module, remote SI module
- Wireless base unit
 - One unit to control the entire wireless network
 - EtherNet/IP™ and PROFINET compatible
 - Max. 1280 inputs/1280 outputs
 - Maximum number of slaves that can be connected to one master without need for communication cables:
 - 127 for EtherNet/IP™
 - 31 for PROFINET.
- Remote module
 - Management of analogue, digital and pneumatic product
- Wireless system
 - Electrical noise resistant
 - Radio wave propagation in the 2.4 GHz ISM high frequency band
 - Frequency hopping – every 5 ms
 - Data encryption.
- Decentralised system, point-to-multipoint communication.
 - Only one IP address for managing the complete wireless system.
 - Wireless communication range: 10 metres.

Solenoid valves

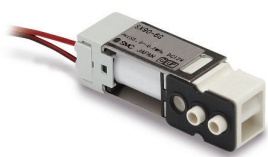

2/3-port solenoid valve

SX90 Series

- High flow up to 90 l/min at 2 bar
- Fluid: air, oxygen, inert gas
- Reduced power consumption (0.7 W)
- Valve type: NC, universal
- Low profile
- Long service life: 10 million cycles.

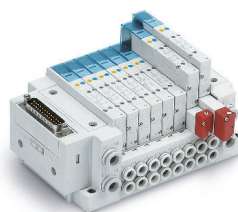

5-port solenoid valve

 SY Series

- Fluid: air
- Flow rate: up to 1535 l/min
- Low power consumption: 0.1 W
- Operating pressure range: -100 kPa to 0.7 MPa (high pressure type: 1 MPa)
- Enclosure: IP67



Direct operated 2-port solenoid valve

 VX2 Series

- Fluid: air, water, steam, medium vacuum, oil
- Reduced power consumption (4.5 W)
- Valve type: NC, NO
- Port size: 1/8" to 1/2"
- One-touch fitting: 6 to 12 mm
- Orifice size: 2 to 10 mm.



5-port solenoid valves

 VQC Series

- Fluid: air
- Flow rate: up to 4350 l/min
- Low power consumption: 0.4 W
- Operating pressure range: 0,1 MPa to 0.7 MPa (high pressure type: 1 MPa)
- Enclosure: IP67.



Compact direct operated 2-port solenoid valve

 VDW Series

- Fluid: air, water, medium vacuum
- Reduced power consumption (2.5 W)
- Valve type: NC
- Port size: M5 to 1/8"
- One-touch fitting: 3.2 to 6 mm
- Orifice size: 1 to 3.2 mm.

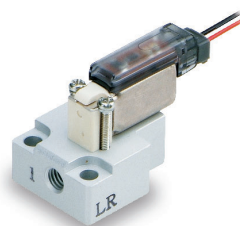

3-port solenoid valve

 S070 Series

- Fluid: air
- Flow rate: up to 15 l/min
- Valve width: 7 mm
- Weight: 5 g (single unit valve)
- Operation noise: 38 dB(A) or less.



Zero differential pressure type pilot operated 2-port solenoid valve

 VXZ Series

- Fluid: air, water, heated water, oil, high temperature oil
- Valve type: NC, NO
- Port size: 1/4" to 1"
- One-touch fitting: 10 to 12 mm
- Orifice size: 10 to 25 mm.

Angle seat valves



Angle seat valves

 VXB Series

- Fluid: air, water, steam
- Low pressure loss due to angle seat structure
- Valve type: NC
- Port size: 3/8" to 3/4"
- Orifice size: 11 to 18 mm
- Long service life: 3 million cycles (steam) 5 million cycles (air).



3-port solenoid valve

 V100 Series

- Fluid: air
- Flow rate: up to 24 l/min.
- Low power consumption: 0.1 W
- Operating pressure range: 0 MPa to 0.7 MPa
- Valve width: 10 mm.



Proportional solenoid valves

 PVQ Series

- Fluid: air, inert gas
- Flow rate: up to 100 l/min
- Service life: lasts 25 million cycles
- Repeatability: 3 % or less
- Can be used for vacuum applications.

Regulators



Electro-pneumatic regulator

 ITV1000/2000/3000 Series

- Controls air pressure in proportion to an electric signal
- Available in MPa, kgf/cm², bar, PSI, and kPa units
- Pressure range of 0.005 to 0.9 MPa
- Available port sizes M5 and 3/8
- Mounting bracket option.



Water regulator

 WR110 Series

- Pressure adjustment of water line.
- Set pressure range: 0.08 to 0.39 MPa / 0.05 to 0.69 MPa.
- Locking system. Resistant body material: brass
- Optional pressure gauge
- Port size: Rc1/8, 1/4, NPT 1/8, 1/4.



Compact electro-pneumatic regulator

 ITV0000 Series

- Built-in one-touch fitting
- Pressure range of 0.001 to 0.9 MPa
- Error indication LED
- High stability
- High response time.



Oxygen regulator

SRA Series

- Fluid: air, oxygen
- Set pressure range: 0.01 to 0.1 MPa
- Port size: Rc1/8, Ø 8 O.D. tubing
- Flow rate range 0.2 to 6 l/min
- Oil-free.

Water filters



Water strainer

 WF300 Series

- Removal of foreign matter in water line.
- Mesh: 25, 50, 70, 100 microns.
- Port size: Rc 1/4, 3/8, 1/2.
- Replaceable stainless steel mesh.
- Body material: bronze casted.

Chillers



Thermo-chiller



HRS Series

- Cooling capacity (50 Hz)
1100 W/1700 W/2100 W/2600 W/
4700 W/4900 W
- Lightweight 43 kg/73 kg
- Temperature stability: ± 0.1 °C
- Temperature range setting: 5 to
40 °C
- International standard: CE, UL.



Thermo-chiller (basic type)



HRSE Series

- Large energy saving by triple control!
- Power consumption 33 % energy saving
- Cooling capacity 1000 W, 1400 W, 1900 W
- Temperature stability ± 2.0 °C
- Set temperature range 10 to 30 °C
- Maintenance free: magnet pump.

Thermo-chiller (rack mount type)



HRR Series

- Mountable in a 19-inch rack.
- Temperature stability: ± 0.1 °C
- Set temperature range: 10 to 35 °C
- Cooling capacity (50 Hz): 1000 W, 1600 W, 2000 W, 2500 W
- Bypass valve and flow sensor are built in (standard)
- International standards: CE, UL.



Thermo-con (rack mount type)



HECE Series

- Mountable in a 19-inch rack
- Cooling capacity 200 W, 400 W, 510 W, 800 W, 1000 W, 1200 W
- Temperature stability ± 0.01 to 0.03 °C
- Set temperature range 10 to 60 °C
- Learning control function
- Low vibration, low noise.



Thermo-con



HEC Series

- Temperature stability: ± 0.01 to 0.03 °C
- Set temperature range: 10 to 60 °C
- Cooling capacity: 600 W, 1200 W
- Type of circulating fluid: water, fluorinated chemicals
- International standards: CE, UL.

Dryers



Membrane air dryer



IDG Series

- Possible to easily supply dry air using the hollow fibre membrane
- Non-fluorocarbon
- Power supply not required
- Compatible with low dew point (-60 °C)
- No vibration or heat discharge
- Dew point indicator.

Air line equipment



Modular F.R.L. units



AC-B Series

- Filter + Regulator + Lubricator
- Body size: 20, 25, 30, 40, 50, 55, 60
- Port Size: 1/8, 1/4, 3/8, 1/2, 3/4, 1
- Max. operating pressure: 1.0 MPa
- Attachments.

Fittings



Fluoropolymer fitting



LQ Series

- High purity fluoropolymer fitting
- Threaded and tubing connection
- Maximum operating pressure (at 20°): 1 MPa
- Operating temperature: 0 to 200 °C
- Variety of size combinations available.



S Couplers



KKA Series

- S coupler with plug and socket, body material: stainless steel 304
- Seal material: fluoropolymer (special FKM)
- Threads, sizes: R, Rc, from 1/8 to 1/2
- Operating temperature: -5 to 150 °C.

Fluoropolymer tubing



- Operating temperature up to 260 °C
- Wide range of sizes.



Fluoropolymer tubing

TL/TIL Series



Soft fluoropolymer tubing

TD/TID Series



FEP tubing (fluoropolymer)

TH/TIH Series

Sensors

Pressure switches



High-precision digital pressure switch

 ISE20□ Series

- Setting is possible while checking the measured value
- Visualization of setting items
- Delay time: Fastest 1.5 ms or less
- Current consumption: 35 mA or less
- IO-Link compatible
- Copy function/auto-shift function.



High-precision digital pressure switch

 ISE7□/ ISE7□G Series

- Setting is possible while checking the measured value
- Angled display
- Rotable display (336°)
- IO-Link compatible.



Digital flow switch for water

 PF3W Series

- 3-colour/2-screen display
- Integrated temperature sensor
- Grease free, RoHS compliant
- Fluid temperature: 0 to 90 °C (PVC piping type 0 to 70 °C)
- PVC piping type: applicable to deionised water, chemical liquids, etc.

Flow switches



Electromagnetic type digital flow switch

 LFE Series

- Applicable fluids: water, water-soluble coolant
- Compact, lightweight:
 - 56 mm x 40 mm x 90 mm (H x W x D)
 - Weight: 340 g (LFE1□3)
- Reverse flow can be detected
- Operating Fluid temperature: 0 to 85 °C
- Pressure loss: 0.02 MPa or less.

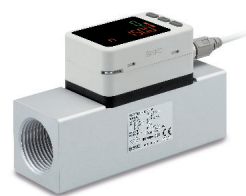

Digital flow switch for large flow

 PF3A7□H Series

- Flow range: max. 12000 l/min
- Flow ratio 100:1
- Through bore construction
- Pressure loss: 75 % reduction (20 kPa to 5 kPa)
- Improved drainage and resistance to foreign matter
- Applicable fluids: air, N₂.



Digital flow switch

 PFMC Series

- 3-colour/2-screen display
- Flow ratio 100:1
- Bypass structure
- Applicable fluids: dry air, N₂.

Cylinders



Corrosion resistant cylinders

 CJ5/CJS Series

- Double acting, single rod cylinders
- All stainless steel external parts
- Special scraper prevents water from entering cylinder.



Compact cylinder

 CQ2 Series

- Double acting, single rod, compact cylinder
- Can mount small auto switches on four surfaces
- No protrusion of auto switch.



Hygienic design cylinder

 HY Series

- A water resistant cylinder configured for easy cleaning
- Service life - five times longer than water resistant cylinders
- External seal material: choice of NBR or FKM.

APTech products



Diaphragm valve

AP Series

- Suitable for UHP gas supply line
- Body material: 316L SS secondary remelt
- Air operated type/Manually operated type
- High pressure type: max. 3000 psig (20.7 MPa).



Regulator

KT Series

- Single stage regulator
- Inlet pressure: max. 10000 psig (69 MPa)
- Body material: stainless steel or brass
- Self-relieving or non-relieving available.



Regulator

AK Series

- Single or two stage regulator for general applications
- High inlet pressure type: max. 3500 psig (24.1 MPa)
- Body material: stainless steel and brass available
- Corrosion resistant Ni-Cr-Mo Alloy (2.4602) internals available.

SMC's Global Service Network

Europe

Germany **SMC Deutschland GmbH**

Boschring 13-15, 63329 Egelsbach, Germany
Phone: (0) 6103/402-0 Fax: (0) 6103/402-139

Switzerland **SMC Schweiz AG**

Dorfstrasse 7, Postfach, 8484 Weisslingen, Switzerland
Phone: 052/396 31 31 Fax: 052/396 31 91

U.K. **SMC Pneumatics (U.K.) Ltd.**

Vincent Avenue, Crownhill, Milton Keynes, Buckinghamshire MK8 0AN, United Kingdom
Phone: 0845-121-5122 Fax: 01908 555064

France **SMC France**

1, Boulevard de Strasbourg, Parc Gustave Eiffel
Bussy Saint Georges F-77607 Marne La Vallée Cedex 3, France
Phone: (0)1-6476 1000 Fax: (0)1-6476 1010

Spain/Portugal **SMC España S.A.**

Zuazobidea 14, 01015 Vitoria, Spain
Phone: 945184100 Fax: 945-184 510

Italy **SMC Italia S.p.A.**

Via delle Donne Lavoratrici - 20861 Brugherio (MB), Italy
Phone: +39 03990691

Greece **SMC Italia Hellas Branch**

Tatoiou 103, Metamorphosi. 14451 Attica, Greece
Phone: 210 2717265

Ireland **SMC Industrial Automation (Ireland) Ltd.**

2002 Citywest Business Campus, Naas Road, Saggart, Co. Dublin, Ireland
Phone: (0)1-403 9000 Fax: (0)1-464-0500

Netherlands **SMC Nederland BV**

De Ruyterkade 120, NL-1011 AB Amsterdam, The Netherlands
Phone: (0)20-5318888 Fax: (0)20-5318880

Belgium **SMC Belgium NV/SA**

Ternesselei 232, 2160 Wommelgem, Belgium
Phone: +32-3-355-1464 Fax: +32-3-355-1466

Denmark **SMC Danmark A/S**

Egeskovvej 1, DK-8700 Horsens, Denmark
Phone: 70252900 Fax: 70252901

Austria **SMC Pneumatik GmbH (Austria)**

Girakstrasse 8, AT-2100 Korneuburg, Austria
Phone: 2262 62 280 Fax: 2262 62 285

Czech Republic **SMC Industrial Automation CZ s.r.o.**

Hudcova 78a, CZ-61200 Brno, Czech Republic
Phone: 5 414 24611 Fax: 5 412 18034

Hungary **SMC Hungary Ipari Automatizálási Kft.**

Torbágy u. 19, HU-2045 Törökbálint, Hungary
Phone: +36 23 513 000 Fax: +36 23 513 001

Poland **SMC Industrial Automation Sp. z o.o.**

ul. Stefana Batorego 10A. Pass, 05-870 Blonie, Poland
Tel. (+48) 22 344 40 00 Fax (+48) 22 344 40 05

Slovakia **SMC Priemysel'na Automatizácia Spol s.r.o.**

Fantranská 1223, Teplicka nad vahom, 01301, Slovakia
Phone: 41-321321-1 Fax: 41-321321-0

Slovenia **SMC Industrijska Avtomatika d.o.o.**

Mirnska cesta 7, SLO-8210 Trebnje, Slovenia
Phone: 7388 5412 Fax: 7388 5435

Bulgaria **SMC Industrial Automation Bulgaria EOOD**

Business Park Sofia, Building 8-6th floor, BG-1715 Sofia, Bulgaria
Phone: 2 9744492 Fax: 2 9744519

Croatia **SMC Industrijska Avtomatika d.o.o.**

Zagrebac'ka Avenija 104, 10 000 Zagreb, Croatia
Phone: 1 370 72 88

Bosnia-Herzegovina <Distributor> **A.M. Pneumatik d.o.o.**

Ul. Goli Brijeg br. 64, BA-75000 Tuzla, Bosnia and Herzegovina
Phone: 352 821 81 Fax: 352 821 81

Serbia <Distributor> **BEST PNEUMATICS d.o.o.**

Toplice Milana 14A, RS-11050 Beograd, Serbia
Phone: +381-113221758 Fax: +381-113227571

Ukraine <Distributor> **PNEUMOTEC Corp.**

Vyshgorodskaya str., 23A, r.2, UA-04074, Kiev, Ukraine
Phone: 44 4606177 Fax: 44 4606177

Albania <Sales partner> **SMC Industrijska Avtomatika d.o.o.**

Mirnska cesta 7, SLO-8210 Trebnje, Slovenia
Phone: +386 7388 5412 Fax: +386 7388 5435

Macedonia <Sales partner> **SMC Industrial Automation Bulgaria EOOD**

Business Park Sofia, Building 8C, 6th floor, BG-1766 Sofia, Bulgaria
Phone: +359 2 9744492 Fax: +359 2 9744519

Finland **SMC Automation Oy**

PL72, Tiistiniityntie 4, SF-02031 Espoo, Finland
Phone: 207 513513 Fax: 207 513595

Norway **SMC Pneumatics Norway AS**

Vollsveien 13 C, Granfos Næringspark N-1366 Lysaker, Norway
Phone: 67 12 90 20 Fax: 67 12 90 21

Sweden **SMC Automation AB**

Ekhagsvägen 29-31, 141 71 Huddinge, Sweden
Phone: 8 603 12 00 Fax: 8 603 12 90

Estonia **SMC Pneumatics Estonia Oü**

Laki 12, EE-10621 Tallinn, Estonia
Phone: 651 0370 Fax: 651 0371

Latvia **SMC Automation SIA**

Dzelzavas str. 120g, Riga, LV-1021, Latvia
Phone: 781 77 00 Fax: 781 77 01

Lithuania **SMC Pneumatics, UAB**

Zalgirio g.96 LT-09300 Vilnius, Lithuania
Phone: +370-5-230-8118

Romania **SMC Romania S.r.l.**

Str Frunzei 29, Sector 2, Bucharest, Romania
Phone: 213205111 Fax: 213261489

Russia **SMC Pneumatik LLC.**

Business center, building 3, 15 Kondratjevskij prospect,
St.Petersburg, Russia, 195197
Phone: (812) 303-6600 Fax: (812) 303-6601

Kazakhstan LLP "SMC Kazakhstan"

Office 509, 18, Tsiolkovskij str. Astana, Rep. of Kazakhstan
Phone: (7172) 541-407

Turkey **SMC Turkey Otomasyon A.S.**

Halkali Merkez Mah, Basın Ekspres Cad,
Capital Tower No:9 Kat:11, 34303, Küçükçekmece / Istanbul, Turkey
Phone: 212-489-0440 Fax: 212-489-0437

Africa

Casablanca Branch **SMC France**

Parc Industriel CFCIM Ouled Salah. Bâtiment N° 2, Lot N° 2, 1er Etage.
Ouled Salah. 27182 Casablanca - Morocco
Phone: 33 (0)1-72846125

Tunisia <Distributor> **Byms**

9 rue de Plastic ZI Sidi Rezig BP 176 2033 Megrine Tunisia
Phone: (71) 428-272 Fax: (71) 427-758

Algeria <Distributor> **Electric Center**

8 Bis Rue Ain Soltan, Les Oliviers, Kouba, Alger
Phone: + 33 2 43 77 47 28 Fax: + 33 2 43 77 01 34

Egypt <Distributor> **Saadani Trading & Industrial Services**

94 Ismail El Fangari St., Nasr City, Cairo, Egypt
Phone: 2-402 9662/2-262 3527 Fax: 2-402 5669

Nigeria <Distributor> **Faraday Engineering Company Ltd.**

24 Obafemi Awolowo Way, Bonfei Plaza, Second Floor,
Ikeja Lagos State, Nigeria
Phone: (01)4967615 Fax: (01)4967615

South Africa **SMC Corporation ZA (Pty) Ltd.**

Unit 4 Midrand Central Business Park, 1019 Morkels Close
Midrand 1682 Johannesburg, South Africa
Phone: +27-11-568-2407

Côte d'Ivoire <Distributor> **Afrique Industries**

Zone 4C rue Fleming, 26 BP 931, Abidjan
Phone: +225-21-244-604 Fax: +225-21-351-674

Senegal <Distributor> **Codex**

40 avenue Jean Jaures, Dakar
Phone: +221-773-33-75-48 Fax: +221-33-842-03-36

Cameroon <Distributor> **TMC**

1871 Boulevard Liberté, BP 1976, Douala
Phone: +237-696-03-22-01 Fax: +237-233-43-11-92

Kenya <Distributor> **Flow Controls Ltd.**

Off Lusaka Road, Pemba Street, Nairobi, Kenya
Phone: +254-555-808 Fax: +254-551-880

With 500 sales offices in 83 countries worldwide, our sales force of over 8,232 maintains close communication with customers.

Asia/Oceania

Japan **SMC Corporation**

Akihabara UDX 15F, 4-14-1, Sotokanda, Chiyoda-ku, Tokyo 101-0021, Japan
TEL: 03-5207-8249 Fax: 03-5298-5362

China <Beijing/Shanghai> **SMC (China) Co., Ltd.**

A2, XingSheng Street, BDA, Beijing, 100176 P.R. China
Phone: (010) 67885566 Fax: (010) 67881837

China <Guangzhou> **SMC Automation (Guangzhou) Limited**

2, Dongming Road 3, Science Park Guangzhou Hi-Tech Industrial
Development Zone, Guangzhou, P.R. China
Phone: (020) 28397668 Fax: (020) 28397669

Hong Kong <Hong Kong/South China> **SMC Pneumatics (Hong Kong) Ltd.**

29/F, Clifford Centre, 778-784 Cheung Sha Wan Road,
Kowloon, Hong Kong, China
Phone: 2744-0121 Fax: 2785-1314

Taiwan **SMC Pneumatics (Taiwan) Co., Ltd.**

No.16, Lane 205, Nansan Rd., Sec.2, Luzhu-hsian,
Taoyuan-hsien, Taiwan
Phone: (03) 322-3443 Fax: (03) 322-3387

Korea **SMC Pneumatics Korea Co., Ltd.**

Scout B/D 8F, 14, Gukhoe-daero 62-gil (Yeouido-dong),
Yeongdeungpo-gu, Seoul, 150-914, Korea
Phone: +82-(02) 3219-0700 Fax: +82-(02) 3219-0702

Singapore **SMC Pneumatics (S.E.A.) Pte. Ltd. (Sales subsidiary)**

33, Tuas Avenue 8, Singapore 639251
Phone: 6861-0888 Fax: 6861-1889

Malaysia **SMC Automation (Malaysia) Sdn Bhd.**

Lot 36, Jalan Delima 1/1, Subang Hi-Tech Industrial Park, Batu Tiga,
47500 Subang Jaya, Selangor, Malaysia
Phone: +60-(03) 56350590 Fax: +60-(03) 56350602

Thailand **SMC (Thailand) Ltd.**

134/6 Moo 5, Tiwanon Road, Bangkadi Amphur, Muang,
Patumthani 12000, Thailand
Phone: (02) 963-7099 Fax: (02) 501-2937

Philippines **Shoketsu SMC Corporation**

Building 7, Don Mariano Lim Industrial Complex,
Alabang-Zapote Road, Almanza, Las Piñas City, Philippines 1740
Phone: (02) 809-0565 Fax: (02) 809-0586

India **SMC Pneumatics (India) Pvt. Ltd.**

A-4, Sector-88, Noida-201 305 India
Phone: 0120-4780222, 2449222 Fax: 0120-2558933

Australia **SMC Pneumatics (Australia) Pty. Ltd.**

14-18 Hudson Avenue, Castle Hill, Sydney,
New South Wales 2154, Australia
Phone: (02) 93548222 Fax: (02) 93548252

New Zealand **SMC Pneumatics (N.Z.) Ltd.**

5 Pacific Rise Mt Wellington Auckland 1060,
New Zealand (P.O. Box 62-226, Sylvia Park, Auckland, 1644)
Phone: (09) 573-7007 Fax: (09) 573-7002

Israel <Distributor> **Baccara Geva A.C.S. Ltd.**

Kvutzat Geva 1891500, Israel
Phone: 04-653-5960 Fax: 04-653-1445

Indonesia **PT. SMC Pneumatics Indonesia**

EJIP Industrial Park Plot 6J-1 Cikarang Selatan - Bekasi
17550 Indonesia
Phone: (02)1897-1123 Fax: (02)1897-0517

Vietnam **SMC Corporation (Vietnam) Co., Ltd.**

No. 63, Lo Lu Street, Truong Thanh Ward, District 9, HCMC, Vietnam
Phone: +84-(0) 8-6281-1110 Fax: +84-(0) 8-6281-1120

Pakistan <Distributor> **Jubilee Corporation**

First Floor, Fakhri Trade Centre Shahrah-e-Liaquat P.O. Box 677
Karachi 74200 - Pakistan
Phone: 21-243 9070 / 21-243 8449 Fax: 21-241 4589

Sri Lanka <Distributor> **Electro-Serv (Pvt.) Ltd.**

124, Nawala Road, Narahenpita, Colombo 5, Sri Lanka
Phone: (011) 258-1104 Fax: (011) 250-1691

U.A.E **SMC Pneumatics Middle East FZE**

P.O. Box 261035, Jebel Ali, Dubai, United Arab Emirates
Phone: 4 801 5900 Fax: 4 801 5988

Kuwait <Distributor> **Esco Trading Est.**

Al Raqum Building, Tunis St.P.O.Box 44400 Hawally, Kuwait-ZIP: 32058
Phone: 22643710/22634777 Fax: 22643709

Saudi Arabia <Distributor> **Alsaggaf Trading Co.**

P.O Box 3385 Jeddah 21471 Saudi Arabia
Phone: 2-673 1857, 2-676 1574 Fax: 2-670 8173

Bahrain <Distributor> **Mohammed Jalal & Sons W.L.L. Technical & Automotive Services**

239, Sh. Salman Highway, P.O. Box 747, Bahrain, A. Gulf
Phone: 17252606 Fax: 17254638

Bangladesh <Distributor> **Chemie International**

B-20/28 Babor Road (Gr.Floor) Mohammadpur,
Dhaka - 1207 Bangladesh
Phone: 9132538/0171-546863 Fax: 9131512

Qatar <Distributor> **INTECHS WLL**

P.O.Box 37956, Doha, Qatar
Phone: 4430035 Fax: 4430025

Oman <Distributor> **Al Wadood Modern Enterprises LLC**

P.O. Box 154, Rusayl - behind Amiantit Oman, Muscat, Sultanate of Oman
Phone: +968-2442 3434 Fax: +968-2442 2349

MYANMAR <Distributor> **MYANMAR GOLDEN TOP CO., LTD.**

No.25(A)South Race Course Street, Tamwe Township, Yangon, Myanmar
Phone: +95 01-557-886

America

U.S.A. **SMC Corporation of America**

10100 SMC Blvd. Noblesville IN 46060, U.S.A.
Phone: 317-899-4440 Fax: 317-899-0819

Canada **SMC Pneumatics (Canada) Ltd.**

6700 Millcreek Drive, Unit #3, Mississauga, ON L5N 8B3, Toronto
Phone: +1-905-812-0400 Fax: +1-905-812-8686

Mexico **SMC Corporation (Mexico), S.A. de C.V.**

Carr. Silao-Trejo K.M. 2.5 S/N Predio San Jose del Durazno
C.P. 36100, Silao, Gto. Mexico
Phone: 472-72-2-55-00 Fax: 472-72-2-59-44, 472-72-2-59-46

Brazil **SMC Pneumáticos do Brasil Ltda.**

Av. Piraporinha, 777 Bairro Planalto, São Bernardo do Campo
São Paulo, Brazil ZIP : 09891-001
Phone: 11-4082-0777 Fax: 11-4082-0685

Chile **SMC Pneumatics (Chile) S.A.**

Av. La Montana, #1115 P. Norte km. 16,5
Parque Industrial Valle Grande, Lampa, Santiago, Chile
Phone: +56-2-270-86-00 Fax: +56-2-270-86-01

Colombia **SMC Pneumatics (Chile) S.A.**

Av. La Montana, #1115 P. Norte km. 16,5
Parque Industrial Valle Grande, Lampa, Santiago, Chile
Phone: +56-2-270-86-00 Fax: +56-2-270-86-01

Argentina **SMC Argentina S.A.**

Austria Norte 1831, Troncos del Talar,
Parque Industrial Tigre, Buenos Aires - Argentina
Phone/Fax: +54-011-4555-5762

Bolivia **SMC Pneumatics Bolivia S.r.l.**

Av. Canal Cotoca # 2635 (entre Calle 9 y 10) Santa Cruz, Bolivia
Phone: (0) 3-3649957 Fax: (0) 3-3649959

Venezuela **SMC Neumatica Venezuela S.A.**

Ave. Michelena Zona Industrial Edificio Canaima Local 4
Valencia-Edo Carabobo, Venezuela
Phone: 241-8345617 Fax: 241-8348258

Peru **SMC CORPORATION PERU S.A.C.**

Calle Andres Reyes 191, San Isidro, Lima, LIMA27, Peru
Phone: 1-4401280 Fax: 1-4401280

Ecuador <Distributor> **ASSISTECH CIA. LTDA.**

Calle de Los Eucaliptos E3-42 y De los Cipreses Quito-Ecuador
Phone: 6003690/6003691 6003692/2807963 Fax: 2804750



Expertise – Passion – Automation